

Burner Control Box

For 2-stage forced draught and combi oil/gas burners

Suitable flame detectors:

- Ionisation probe
- UV sensor
- Infra-red flicker detector

INTRODUCTION

The MMG burner control box is capable of controlling and monitoring forced draught and combi oil/gas burners of any nominal rating (tested and approved as per EN 298). The MMG 810.1 model 33 control boxes are also suitable for use in stationary warm air generators (Direct air heaters according to DIN 4794).

Different type and model designations identify the control boxes according to varying national standards, and to some extent, according to programme times.

TYPES AVAILABLE

MMG 810.1	Mod. 32	Art. Nr. 0640120
	Mod. 33	Art. Nr. 0640220
	Mod. 43	Art. Nr. 0642520
	Mod. 45	Art. Nr. 0642620
MMG 811.1	Mod. 33	Art. Nr. 0640520
	Mod. 63	Art. Nr. 0640420

CONSTRUCTIONAL FEATURES

The control box is enclosed in a protective, flame resistant, transparent, plug-in type plastic housing, and includes:

- Synchronous motor with reduction gearing driving cam switch
- Cam switch with informative, coloured programme indicator
- 12-way cam switch assembly controlling the programme sequence
- Electronic components on plug-in printed circuit

The following important indicators and operating controls are situated on the front of the control box:

- Reset button incorporating signal lamp for malfunction (lockout)
- Coloured programme indicator
- Central screw fastening



TECHNICAL DATA

Supply voltage	220 / 240 V (-15... +10%)
AC frequency variations	50 Hz (50 - 60 Hz) result in proportional timing deviations
Fuse rating	max. 10 A rapid, 6 A slow
Power consumption	10 VA
Max. current per output term. 3	2A, cos φ 0.2
term. 4, B	2A, cos φ 0.4
term. 5, 6, C	1A, cos φ 0.4
Total load	5A, cos φ 0.4
Amplifier sensitivity	1 μA
Min. current from UV tube or ionisation probe	5 μA
Flame detector cable	max. 20 m cable length
Air proving switch	1 terminal 4 A, 230 V
Reset delay	none
Flame detector	
- Ionisation probe	
- Infra-red flicker detector	IRD 1020.1 end-on
- UV tube type	UVZ 780 red markings installed radially or axially
Infra red flare detector	IRD 1020
Weight incl. base	350 g
Mounting attitude	any
Insulation standard	IP 44
Permissible ambient temp.	-20° C... +60° C
Classified acc. to EN 298	BTLXN

program timings (sec.)	MMG 810.1				811.1	
	32	33	43	45	33	63
Model						
Waiting time at start-up	tw	9	9	9	9	6
Max. reaction time for air proving switch	tlw	6	6	6	6	5
Pre-purge time	tv1	24	24	40	40	55
Pre-ignition time	tvz	3	3	3	3	3
T. ignition time	tz	6	6	6	8	5.5
Safety time	ts	2	3	3	5	3
Time delay term.6 / term.C	tv2	10	10	10	10	6

For external resetting, the remote reset device FR 870 (art. No. 70700) can be utilized. (Refer to doc. 750).

TECHNICAL FEATURES

1. Flame detection

The following types of flame detector can be employed:

- Ionisation electrode, where the mains supply provides a neutral earth connection. Suitable for gas burners (signal current from flame cannot be influenced by interference from ignition spark).
- UV sensor type UVZ 780 red, suitable for gas and combi burners.
- Infra-red flicker detector type IRD 1020.1 for all types of burner.

2. Burner Control

- The burner controls features a low-voltage protection. If the supply voltage drops below 160 V during operation, the burner switches-off. When the supply voltage raises above 180 V, the burner performs a restart independently.
- The MMG control boxes only operate when a load is connected to terminal 5. If the fuel valve is isolated during the pre-purge by way of an external switch contact, a resistor with a value of max. 22 k Ω /4 watts, must be connected between terminals 5 and 8.
- Functional check of the air proving switch before the start, and monitoring of the air pressure during pre-purge as well as during normal operation. In normal use, switch contacts with a rating of 4 A / 220 V are sufficient.
- On the MMG 810.1, switch contacts (e.g. valve end contact) can be wired between terminals 1 and 9. These contacts are checked for proper closure during the burner start phase. The connection between terminals 1 and 9 must be complete during the start phase.
- The MMG 810.1 control box monitors the ignition spark if the UVZ 780 (red) is used for flame detection, and terminals C and 9 are wired together.

3. Safety

The design/construction and programme sequence of the control boxes in the MMG series conform to the present applicable European standards and regulations.

4. Installation

At the base:

- 3 earth terminals with additional terminal for burner earthing
- 3 neutral terminals with internal permanent connection to neutral terminal 8
- 2 independent spare terminals (S1 and S2)
- extra terminals A, B and C are standard
- 2 slide-in plates and 2 easy knock out holes plus 2 knock out holes in the base bottom facilitate the base wiring

Please note

To assist trouble-free operation the main neutral connection terminal 8 in the wiring base must be fully tightened. The terminal screws are already in the undone position. To connect a wire to the terminal, the screw only needs to be fastened.

General:

- Can be mounted in any position, insulated as per IP 44 standard (unaffected by water spray). The control box and detector probes should however not be subjected to excessive vibration.
- The applicable installation regulations must be observed during installation.

COMMISSIONING AND MAINTENANCE

1. Important

- The wiring must be checked exactly when commissioning the installation. Incorrect wiring could damage the control box, putting the safety of the burner system at risk.
- The chosen fuse rating must not, on any account, be higher than the value given in the technical data. Failure to observe this instruction could, in the case of a short circuit, have serious consequences for the control box or burner system.
- For safety reasons, it must be ensured that the control box performs at least one normal shut-down during every 24 hour period.
- Switch off or disconnect the power before plugging in or unplugging the unit.
- Control boxes are safety devices and should not to be interfered with.

2. Functional Check

During commissioning and after an overhaul of the burner, the following checks have to be carried out:

- a) Starting test with closed manual valve and bridged gas monitor contact:
 - The device must go into a fault condition after the safety period has elapsed.
- b) Close the manual valve in operating position with the gas monitor contact bridged.
 - The device must go into a fault condition after a flame failure.
- c) Air pressure monitor contact interrupted:
 - Device goes into a fault condition.
- d) Bridge air pressure monitor contact before starting:
 - Device must not start.

3. Trouble Shooting

Burner does not go into operation, programme indication remains:

- Electrical connection defective.
- Thermostat or gas monitor "OFF".

Burner does not go into operation, programme indication rotates continuously:

- Air pressure monitor defective, respectively, not in starting position. (Working contact must be open).
- Connection term. 1 - term. 9 interrupted
- mains voltage < 180V

The automatic control switches to fault condition shortly after the start of the pre-purge time (line within the blue zone):

- Air pressure monitor contact does not close.
- No load on terminal 5.
- Flame signal.

Automatic control switches to fault condition during the pre-purging (blue zone):

- No flame formation (ignition missing, valve does not open, etc.)
- No flame signal or too weak flame signal (flame does not adhere, poor insulation of the flame detector, burner not properly connected to the earth conductor).

Automatic control switches to fault condition during the operating position (red, resp. green zone):

- Flame lift-off
- Air pressure monitor contact opens
- Flame signal too weak.

SCHEMATIC CONNECTION DIAGRAM AND PROCESS DIAGRAM MMG 810.1

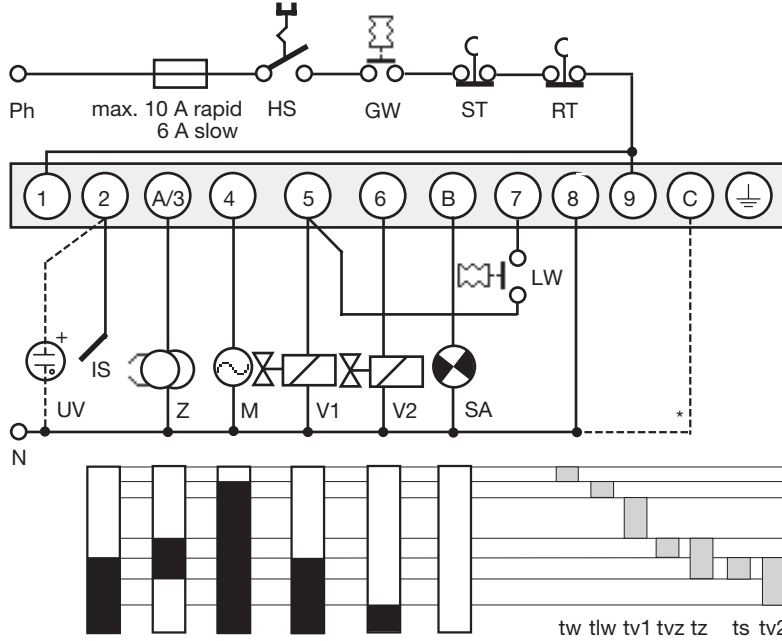

* for ign. spark detection only

- HS Mains switch
- GW Gas pressure switch
- ST Limit thermostat
- RT Control thermostat
- IS Ionisation probe
- UV UV sensor
- Z Ignition
- M Burner motor
- V1 Solenoid valve, 1st-stage
- V2 Solenoid valve, 2nd-stage
- LW Air pressure monitor
- SA External lock-out signal for spark detection only
- SV Safety valve

SCHEMATIC CONNECTION DIAGRAM AND PROCESS DIAGRAM MMG 811.1

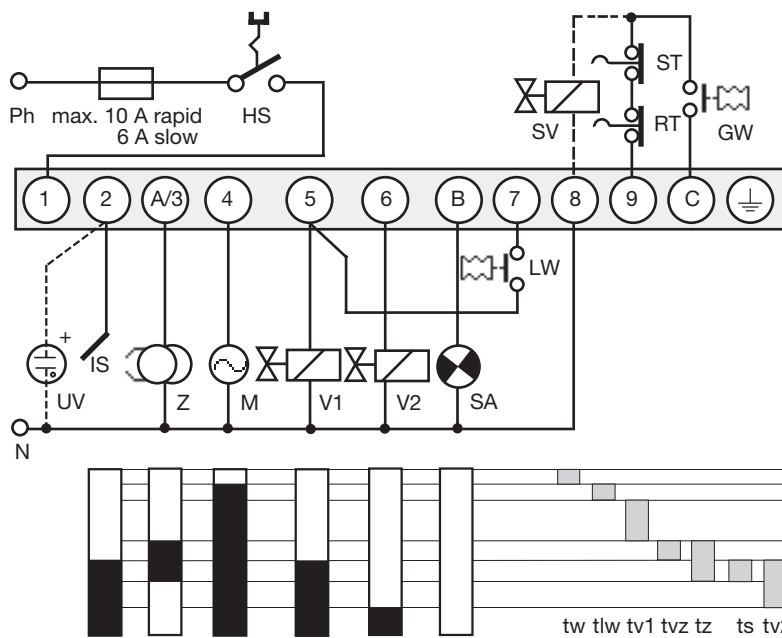

- tw Waiting time at start-up
- tlw Max. reaction time for air proving switch
- tv1 Pre-purge time
- tvz Pre-ignition time
- tz Total ignition time
- ts Safety time
- tv2 Time delay term.6 / term. C

IRD CONNECTION

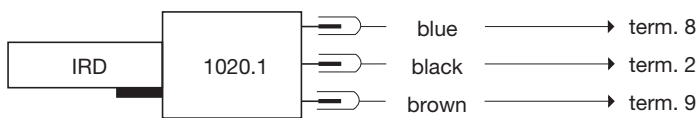

SCHEMATIC DIAGRAMMM MMG 810.1

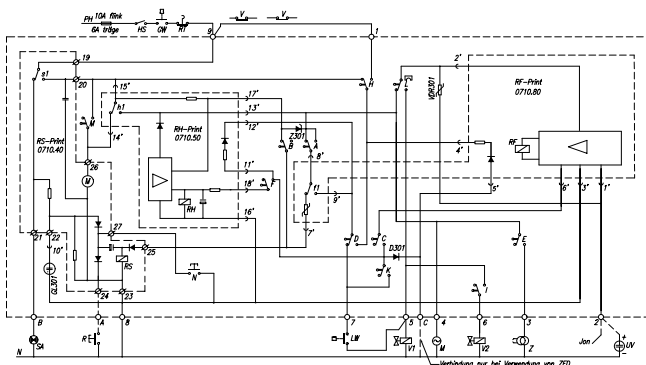

SCHEMATIC DIAGRAMMM MMG 811.1

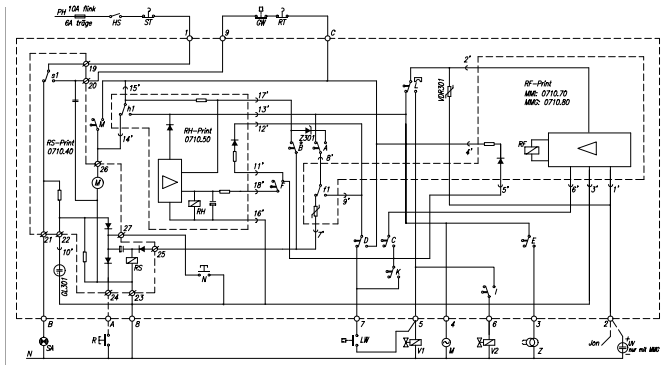

MMG AND SOCKET

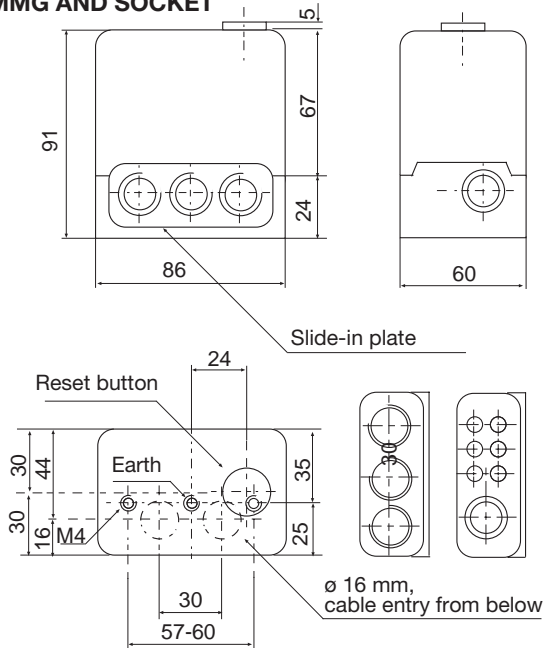

UVZ 780 AND HOLDER

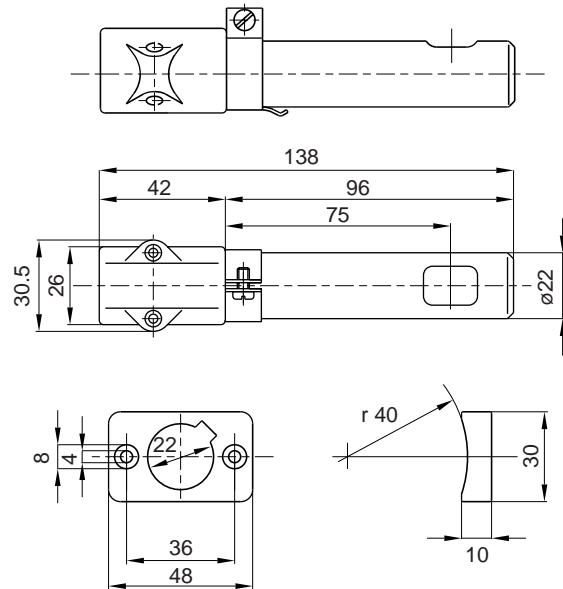

IRD 1020.1

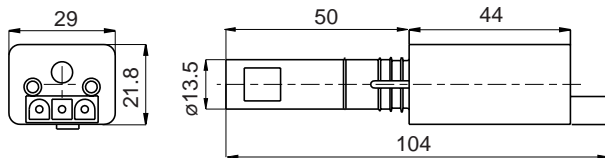

HOLDER M93

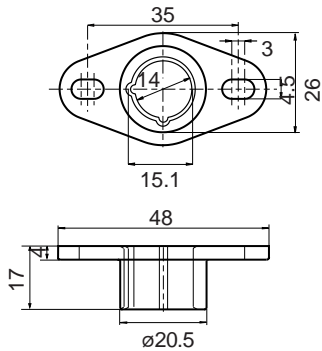

CHECKING THE FLAMESIGNAL

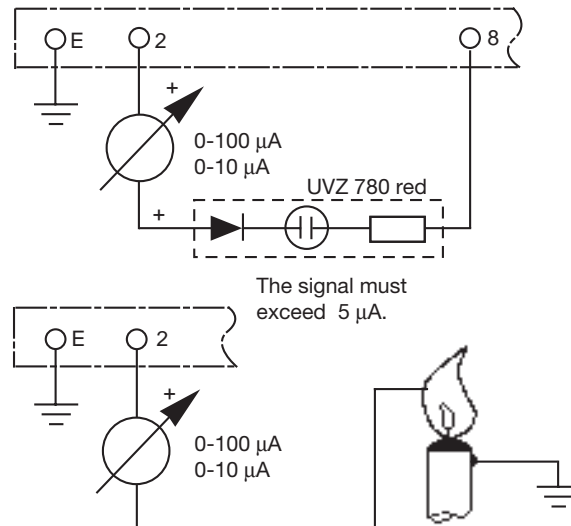

ORDERING INFORMATION

ITEM	DESIGNATION	ITEM NO.
Control box	Type MMG 810.1 mod. 33	0640220
or	Type MMG 811.1 mod. 33	0640520
Socket	Wiring base S98 12-pin	75310
Slide-in plate	Cable terminal plate	70502
or	PG-plate	70503
Flame detector	IRD 1020.1 end-on viewing	16552
Flame detector	UVZ 780 red	18813
IRD mounting flange	IRD Holder M93	59093
UVZ mounting flange	UVZ Holder	18807
Flame detector cable	3-wire, 0.6 m	7236001

The above ordering information refers to the standard version.
Special versions are also included in our product range.

Specifications subject to change without notice.

MMG810.1/811.1

satronic
A Honeywell Company

Satronic AG
Honeywell-Platz 1
Postfach 324
CH-8157 Dielsdorf

Burner Control Box

For high performance forced draught and dual fuel burners in intermittent operation (single or two stage versions).

Suitable flame detectors:

- Ionisation probe
- UV sensor
- Infra-red flicker detector

INTRODUCTION

The TMG 740-3 burner control box is capable of controlling and monitoring medium to high performance forced draught and dual fuel oil/gas burners in single or two stage versions. It can be used, as preferred, for multi-stage or modulating operation with burners of any nominal rating as well as in direct air heaters (as per DIN 4794).

Different model designations identify the control boxes according to programme times for varying national standards, or for special applications e.g. high-speed steam generators. A special version is available for operation with ignition spark monitoring in conformance with French national regulations.

The TMG 740-3 is fully interchangeable with the earlier versions -1 and -2.

CONSTRUCTIONAL FEATURES

The control box is enclosed in a protective, flame resistant, transparent, plug-in type plastic housing, and includes:

- Synchronous motor with gearbox driving cam switch
- Cam switch with informative, coloured programme indicator
- 16-way cam switch assembly controlling the programme sequence
- 2 DC relays and 1 remanence relay on common yoke
- Plug-in printed circuit board with mains transformer, LED display and electronic components

On the underside of the unit are robust plug terminals where the air proving switch and monitoring of the ignition spark can be programmed via two wire links which can be cut as required. The flame detector selection switch is also situated on the the underside of the unit.

The following important indicators and operating controls can be found on the front of the control box:

- Reset button incorporating signal lamp for malfunction (lockout)
- Coloured programme indicator
- Flame signal indicator with 5 LED's
- Central screw fastening



TECHNICAL DATA

Supply voltage	220 / 240 V (-15... +10%) 50 HZ (40 - 60 Hz)
AC frequency variations	result in proportional timing
AC frequency variations deviations	
Fuse rating	10 A rapid, 6 A slow
Power consumption	approx. 15 VA
Max. current per output terminal	4 A
Total	6 A
Sensitivity	
Ionisation input	1.6 μ A
UV input	70 μ A
Min. sensor current	
Ionisation/IR probe	5 μ A = 2 LED
UV tube	250 μ A = 2 LED
Air proving switch	6 A, 220 V
Reset delay	none
Flame detector cable	
Ionisation	50 m normal cable 100 m screened cable
UV tube	100 m normal cable 200 m screened cable
UV tube	UVZ 780 blue low sensitivity UVZ 780 white medium sensitivity UVZ 780 red high sensitivity
Weight incl. base	1100 g
Mounting attitude	any
Insulation standard	IP 44
Permissible ambient temp.	-20° C to +60° C incl.
Classified acc. to EN 298	BTLXN

Model No.	32-32 sec.	63-55 sec.	43-35 sec.	13-53* sec.	63-58 sec.
Pre-purge time supervised	24	60	32	4	60
Pre-purge time with air damper open	30	60	40	6	60
Pre-ignition time fixed	3	4	4	1	4
Start valve safety interval	2	3	3	3	3
Pilot valve safety interval	3	5	3	5	5
Pilot valve switch on time	11	13.5	14	8	16.5
Main valve 1 safety interval	2	5	5	3	8
Valve 1 delay	9	10	10	6	10
Valve 2 delay	6	20	10	4	20
Post-purge	7	16	10	-	16

* For high-speed steam generators. Prescribed ventilation must be verified.

TECHNICAL FEATURES

1. Flame detection

The following types of flame detector can be used:

- Ionisation electrode, where the mains supply provides a neutral earth connection. Suitable for gas burners (signal current from flame cannot be influenced by interference from ignition spark).
- UV sensor type UVZ 780 red, suitable for gas, oil and dual fuel burners.
- Infra-red flicker detector type IRD 820 and 1020 for all types of burner.

The flame signal amplifier is adjusted to the the type of detector probe fitted by using the flame detector selection switch on the underside of the unit. If the IRD flicker detector is used, the selection switch must be adjusted to the "ION" position.

Flame detection is only operational when the switch position selected corresponds to the type of detector probe connected.

By optimally matching the amplifier to the detector probe, considerably longer signal transmission distances with less sensitivity to interference can be achieved.

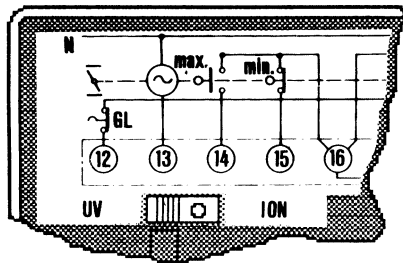

The flame signal current indicator consists of a five stage LED display which shows the signal current continuously. An indication of the strength of the flame signal current is therefore always given. Fluctuations in the monitoring sensitivity can be noticed at an early stage, and appropriate corrective action can be taken.

If the infra-red flicker detector IRD 820 or 920 is employed, the flame signal current indicator on the control box is not relevant. In this case, the IRD indicator is the decisive indication of flame signal strength.

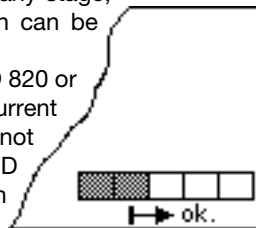

Flame signal current indicator

2. Burner Control

- Burners can be operated with or without post-purge. This varies according to model (see technical data) and is activated when the burner motor is connected to terminal 19.
- Air damper operation is monitored to ensure the nominal air volume during pre-purge and in the starting position before fuel is released. If confirmation of the damper positions "MIN" and "MAX" is not received, the control box start sequence is interrupted.
- The air proving switch is checked for correct operation before the start, and air pressure is monitored during pre-purge as well as during normal operation. In normal use, switch contacts with a rating of 6A/220V are sufficient. Additional switch contacts which are to be monitored can be connected between terminal 18 and the air proving switch working contact. In this case, jumper II on the underside of the control box should be cut.

- A separate connection for a pilot valve PV is provided, which is again closed at the end of the second safety interval. The heat output of the gas flow which is controlled by this valve must not exceed 120kW.
- The terminal for the start valve SV must not be used when connecting the pilot valve PV.
- Together with the start valve SV, a total of 3 power levels are available for use. The gas flow controlled by valves SV, V1 and V2 must lead to a common nozzle unit.
- To determine the heating power of the gas flow controlled by the pilot- and start valve, EN 676 has to be consulted.
- In addition to the built-in button with signal lamp, it is also possible to connect a remote lockout indicator and reset switch.
- For monitoring of the ignition spark, link 1 on the base of the control box must be cut. In this case, flame detection is carried out by a UVZ 780 ultra-violet sensor.

3. Safety

The design and programme sequence employed in the control boxes in the TMG 740-3 series conform to the presently applicable European standards and regulations. The following features exceed the requirements of most standards, and therefore ensure additional safety:

- After a normal shutdown, the stray light test is started immediately by the control box which directs an increased voltage to the UV sensor. The very important extinguishing function of the sensor can therefore be checked. If the fuel valve does not close correctly, or a sensor or amplifier malfunction occurs, shutdown and lockout take place after approx. 20 sec., even if the controlling thermostat is open.
- The contacts responsible for the release of fuel are checked when the programme starts, to ensure that they have not become welded together.

4. Mounting and Electrical Installation

At the base:

- 3 earth terminals, with an additional tag for the burner earth.
- 3 neutral terminals, with a fixed internal through connection to the neutral input, terminal 8.
- 2 separate slide-in plates and 4 fixed, threaded knockouts (PG 11 thread) as well as a wiring opening from below, to facilitate wiring of the base.
- A keyed fit ensures that the wrong control box type cannot be fitted to the base. The corresponding control box designation is shown in lettering on the base.

General:

- Can be mounted in any position, insulated as per IP 44 standard (unaffected by water spray). The control box and detector probes should not however be subjected to excessive vibration. With the UVZ 780 ultra-violet sensor, care should be taken to ensure that a good electrical contact to the burner exists via the metal flange.
- If an ionisation electrode is used, appropriate protective measures are required in order to avoid contact with the electrode while installation work is being carried out. Trouble-free operation with this type of flame detection is not possible if a voltage of over 25 volts is measured between neutral and earth. In this case, provision must be made for a separate isolating transformer.
- The maximum lengths for the detector probe cables, depending on the type of cable installed, are listed in the technical data and must be adhered to without fail. Laying the cables parallel to mains cabling over long distances should be avoided, and the use of multiple core cable is also not permitted.

WIRING DIAGRAMS

IRD CONNECTION

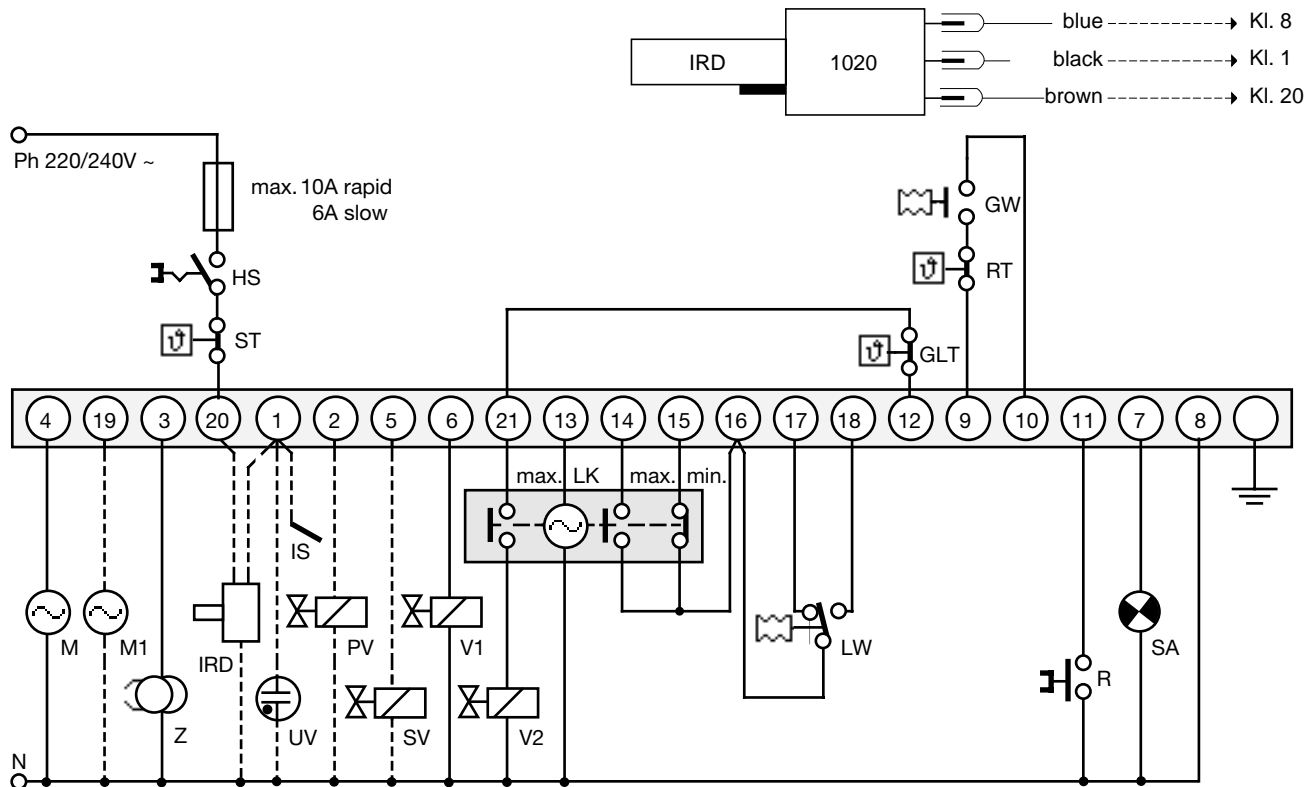

- | | | | |
|-----|-------------------------------|----|--|
| HS | Mains switch | IS | Flame ionisation probe |
| ST | Limit thermostat | PV | Pilot flame gas valve |
| GW | Gas Pressure proving switch | SV | Start flame gas valve |
| RT | Control thermostat | V1 | Main flame gas valve |
| GLT | High/low operation thermostat | V2 | High flame or modulation stage gas valve |
| M | Burner motor | LK | Air damper motor or actuator |
| M1 | Burner motor for post-purge | LW | Air pressure proving switch |
| Z | Ignition transformer | R | Remote reset switch |
| IRD | Infra-red flicker detector | SA | External lockout signal lamp |
| UV | UV-cell | | |

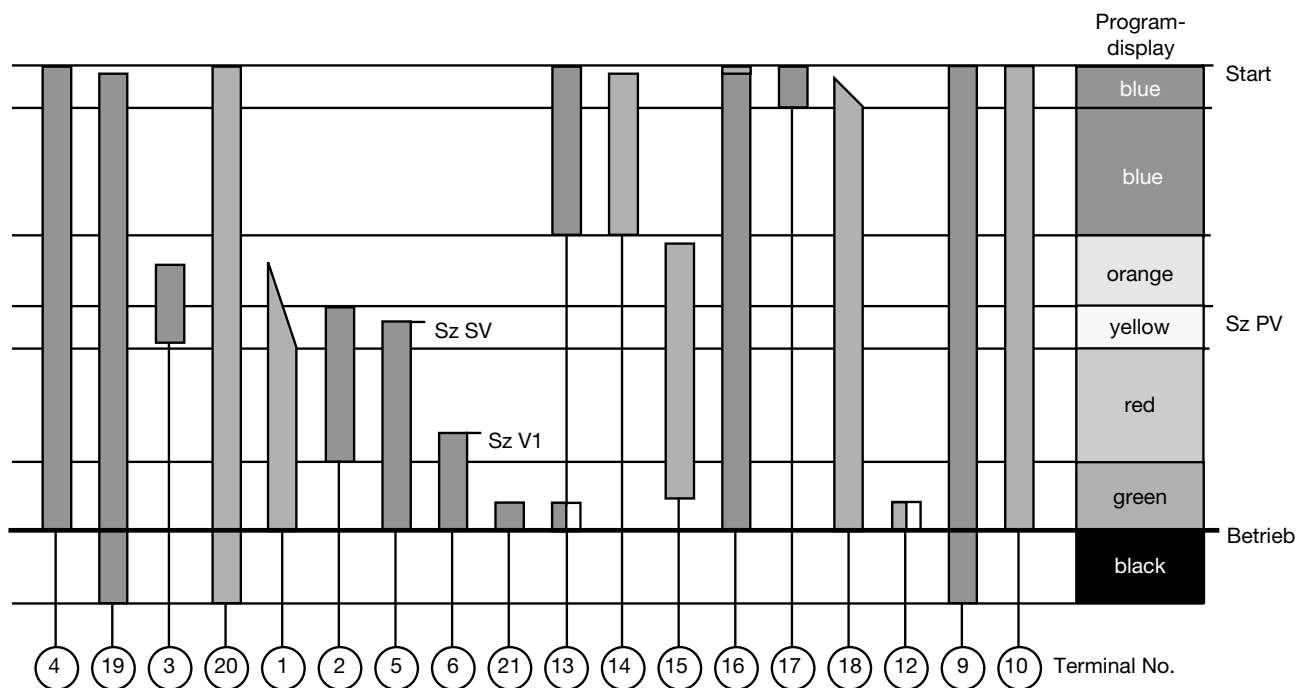

■ required Input

■ Output

COMMISSIONING AND MAINTENANCE

1. Important

The wiring must be checked exactly when commissioning the installation. Incorrect wiring could damage the control box, putting the safety of the burner system at risk. When mounting and wiring the control box, the applicable installation regulations must be observed.

- The chosen fuse rating must not, on any account, be higher than the value listed in the technical data.
- Failure to observe this instruction could, in the case of a short circuit, have serious consequences for the control box or burner system.
- For safety reasons, it must be ensured that the control box performs at least one normal shutdown during every 24 hour period.
- Switch off or disconnect the power before plugging in or unplugging the unit.
- Burner control boxes are safety devices and should not be opened.

2. Routine Checks

An inspection of the technical safety of the flame detection system must be carried out during commissioning of the unit as well as after servicing, or if the system has not been in operation over a long period.

For test a), the gas proving switch should be bridged.

- a) Attempt to start with the hand valve closed:
 - After the first safety interval has elapsed
 - > Lockout
- b) During normal operation, interrupt detector probe or cut off light:
 - In less than 1 sec.
 - > Lockout

Fault finding

Fault finding is considerably simplified by making use of the coloured programme indicator. Irregularities during commissioning, normal operation or a normal shutdown pause can be localised via the programme indicator disc. If a malfunction occurs, it is useful to note the exact position of the indicator before operating the control switch or reset button.

The following list is designed to assist with fault finding.

COLOUR	WHERE	WHAT	REASON
BLUE	beginning	doesn't start	- no power, break in control circuit, air proving switch not in resting position
	line	continuous ventilation lockout	- end switch "MAX" air damper doesn't operate
	end	continuous ventilation lockout	- air proving switch doesn't switch over or is too late
	anywhere	lockout	- end switch "ignition position", air damper doesn't operate
			- stray light
YELLOW	end	lockout	- flame establishment pilot or start valve impossible no flame signal current or too weak (min. 2 LED's) flame detector selector switch set incorrectly
RED	end	lockout	- no flame signal current or too weak after end of second safety interval (double fuel feed burner)
GREEN	end	lockout	- loss of flame during operation, air pressure too low
BLACK	end	lockout	- stray light due to burning on, UVZ sensor tube reached end of life and activates shutoff, defect in flame detector circuit

A test baseplate is available for checking the burner control box functions (model designation UP 7520, item no. 18601)

BURNER 1- OR 2-STAGE

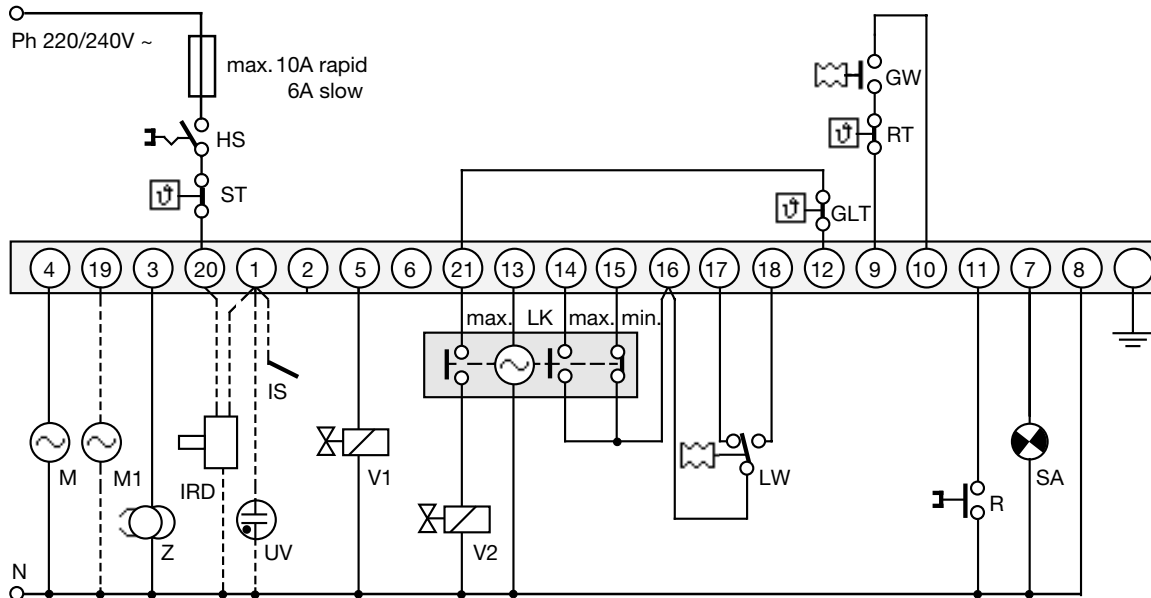

BURNER WITH START-VALVE

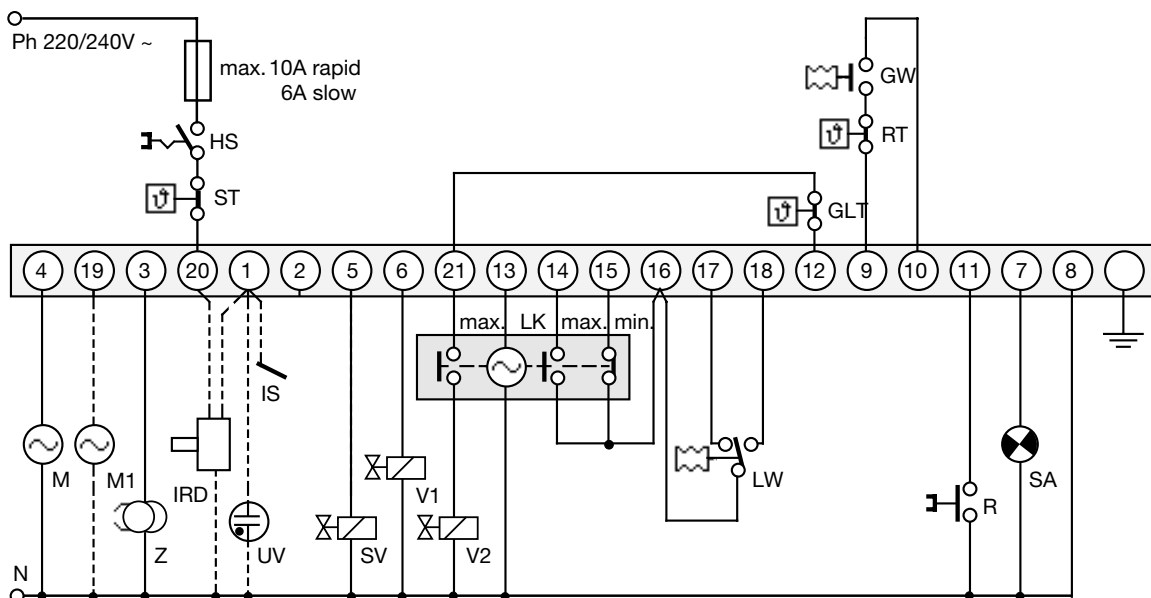

2 NOZZLE BURNER

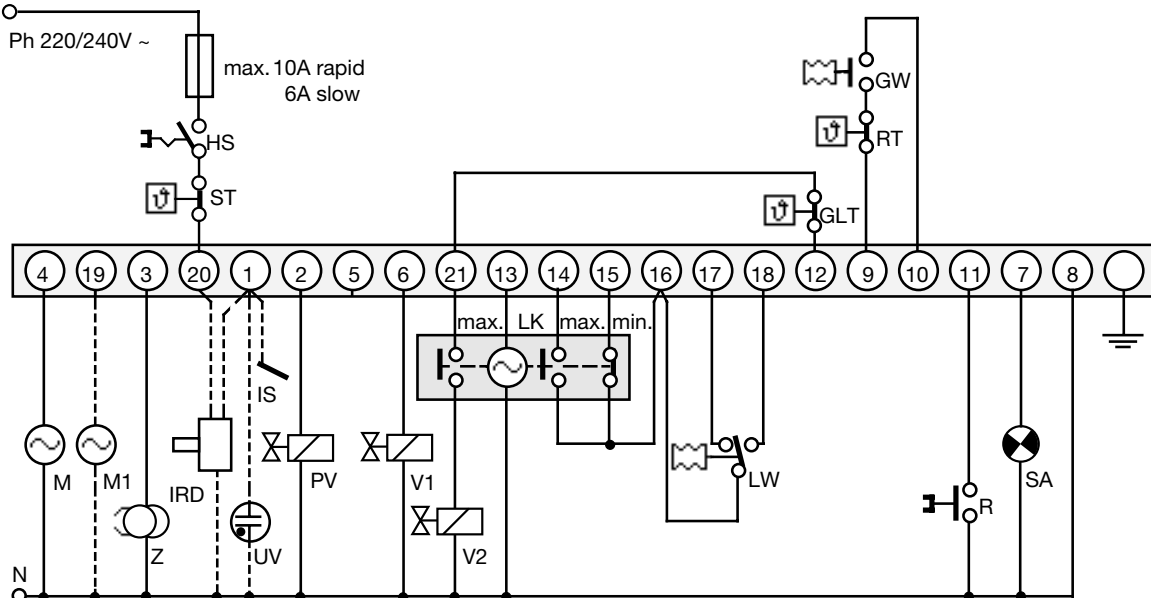

SCHEMATIC DIAGRAMM

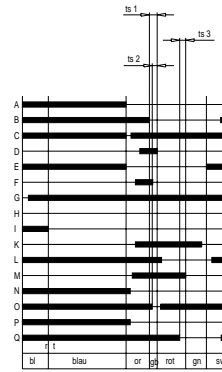
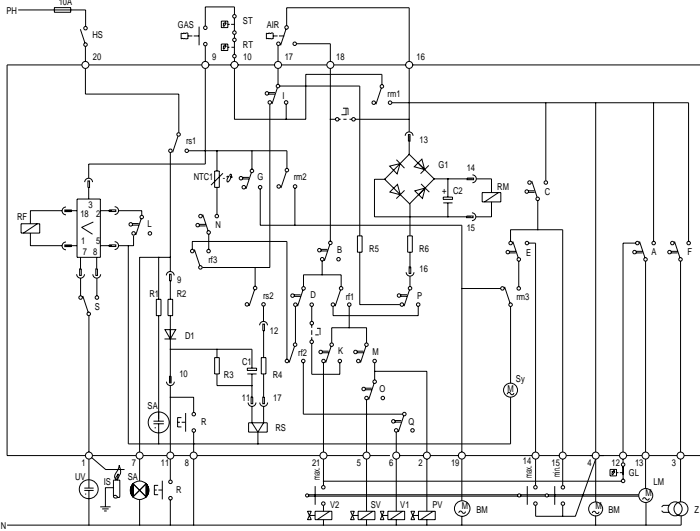

ts1 = Pilot valve safety interval
ts2 = Start valve safety interval
ts3 = Main valve 1 safety interval

I = cut for monitoring of the ignition spark
II = cut for additional switch contacts

TMG 740-3 WITH SOCKET

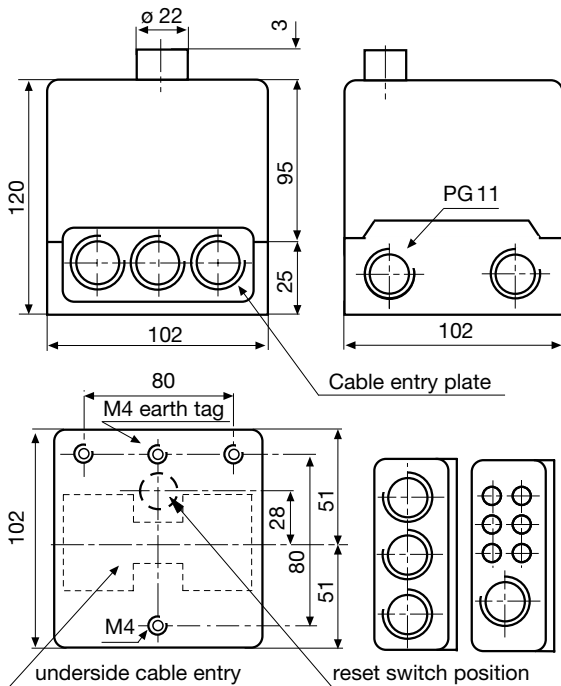

UVZ 780 WITH SUPPORT

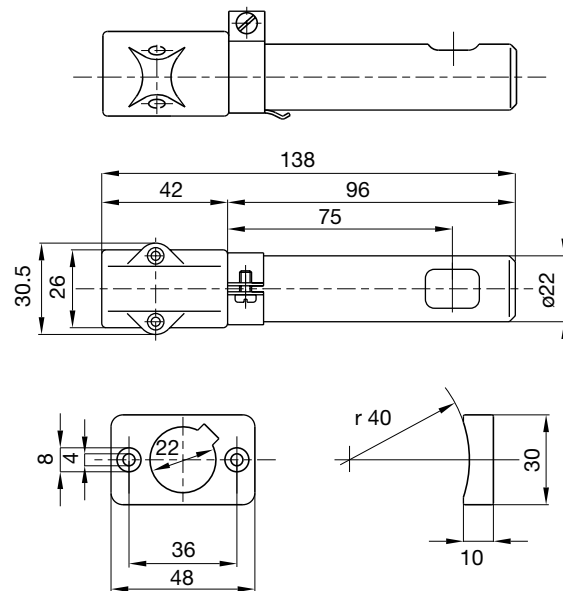

ORDERING INFORMATION

ITEM	DESIGNATION	ITEM NO.
Burner control box	Type TMG 740-3 Mod. 32-32	08211
Socket	Socket TMG	70205
Insert plate	PG-plate	70502
optional	Cable entry plate	70501
Flame detector	UVZ 780 white	18814
or	UVZ 780 blue	18812
or	UVZ 780 red	18813
Flame detector	IRD 820	16201
Flame detector	IRD 1020 end-on viewing	16522
Flame detector	IRD 1020 side-on left	16523
Flame detector	IRD 1020 side-on right	16521
IRD mounting flange	IRD Holder M93	59093
Flame detector cable	3-wire, 0.6 m	7236001

The above ordering information refers to the standard version.
Special versions are also included in our product range.

Specifications subject to change without notice.

TMG 740-3

satronic

A Honeywell Company

Satronic AG
Honeywell-Platz 1
Postfach 324
CH-8157 Dielsdorf